



SSL5001T

Compact non-dimmable LED controller IC

Rev. 2 — 26 June 2014

Product data sheet

1. General description

The SSL5001T is an Integrated Circuit (IC) for driving LED lamps in general lighting applications. It operates in fixed frequency mode. Frequency jitter is implemented to reduce ElectroMagnetic Interference (EMI).

The main benefits of this IC include:

- Constant power mode applications support
- Small Printed-Circuit Board (PCB) footprint and compact solution
- High efficiency (85 % typical)
- Ease of integration and many protection features
- Low electronic Bill Of Material (BOM)
- Constant current and constant voltage operation possible using an optocoupler

The VINCENSE and PROTECT pins are reserved for protection purposes. Input UnderVoltage Protection (UVP), input OverVoltage Protection (OVP), output OVP and output OverTemperature Protection (OTP) can be implemented using a minimum of external components.

The IC provides output power control to 10 % LED current accuracy. The IC has many protection features including easy LED temperature feedback with an external PTC.

Remark: All values are typical values unless otherwise stated

2. Features and benefits

- LED controller IC for driving strings of LEDs or high-voltage LED modules from a rectified mains supply
- Part of a high-efficiency switch mode flyback or buck/boost product family.
 - ◆ Controller-only which can drive an external MOSFET
- Very low supply current during start-up and restart (10 μ A)

- Low supply current during normal operation (0.5 mA without load)
- Applicable in buck/boost and flyback topologies
- Fast transient response through cycle-by-cycle current control:
 - ◆ Low AC mains ripple in LED current
 - ◆ No over or undershoots in the LED current
- Internal protection and features:
 - ◆ UnderVoltage LockOut (UVLO)
 - ◆ Leading Edge Blanking (LEB)
 - ◆ General purpose protection input
 - ◆ OverCurrent Protection (OCP)
 - ◆ Open output protection
 - ◆ Fixed switching frequency with frequency jitter to reduce EMI
 - ◆ Frequency reduction with fixed minimum peak current to maintain high-efficiency at low output power levels
 - ◆ Internal OverTemperature Protection (OTP)
 - ◆ Mains UnderVoltage Protection (UVP) and OverVoltage Protection (OVP)
 - ◆ Output Short Protection (OSP)
- Low component count (see [Figure 3](#)) LED driver solution:
 - ◆ Easy external temperature protection with a PTC
 - ◆ Option for soft-start function
- IC lifetime easily matches or surpasses LED lamp lifetime

3. Applications

The SSL5001T is intended for compact LED lamps with fixed power output for single mains input voltages. Mains input voltages include 100 V, 120 V and 230 V (AC) depending on the voltage rating of the external components. The power range is determined using external components. For a rated power higher than 25 W, additional mains current conditioning circuitry can be required.

4. Quick reference data

Table 1. Quick reference data

Symbol	Parameter	Conditions	Min	Typ	Max	Unit
V_{CC}	supply voltage	operating range	14	-	25	V
I_{CC}	supply current	no load on pin DRIVER	0.4	0.5	0.6	mA
f_{conv}	conversion frequency		62	66.5	71	kHz
$V_{O(DRIVER)max}$	maximum output voltage on pin DRIVER	$V_{CC} > V_{CC(startup)}$	9	10.5	12	V

5. Ordering information

Table 2. Ordering information

Type number	Package		
	Name	Description	Version
SSL5001T	SO8	plastic small outline package; 8 leads; body width 3.9 mm	SOT96-1

6. Block diagram

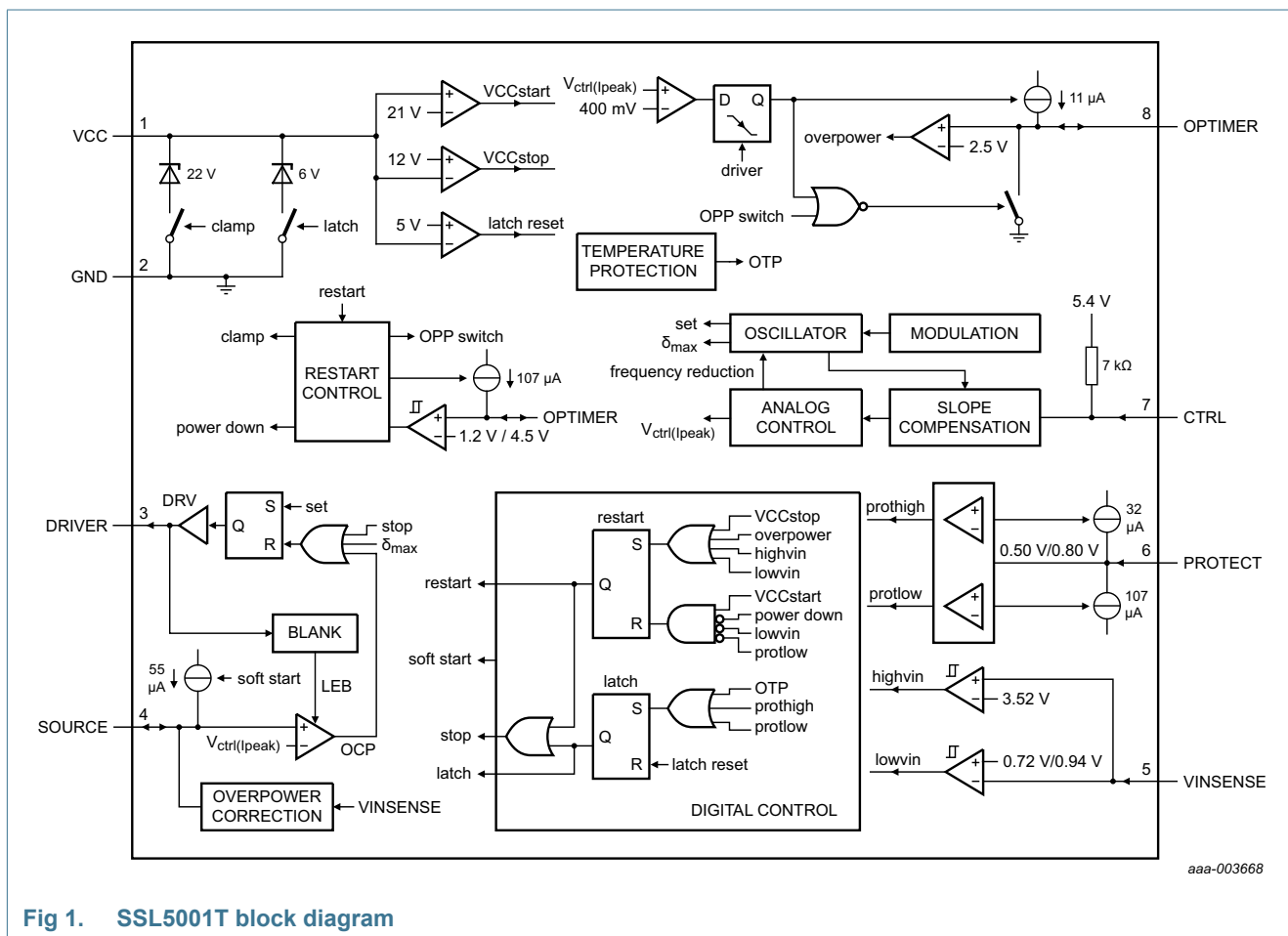
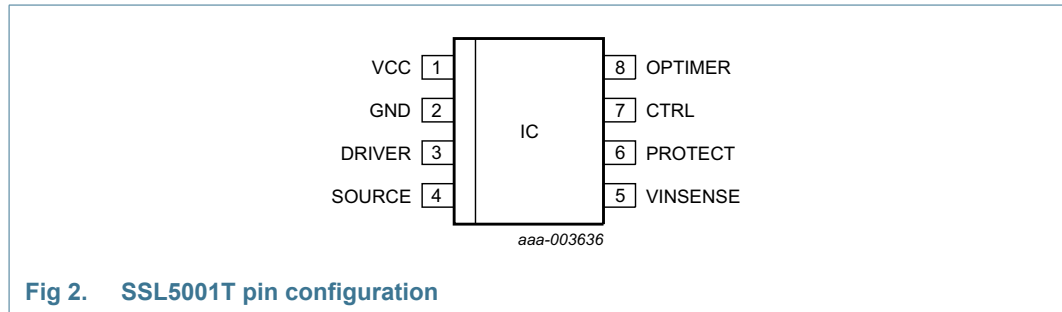

Fig 1. SSL5001T block diagram

7. Pinning information

7.1 Pinning



7.2 Pin description

Table 3. Pin description

Symbol	Pin	Description
VCC	1	supply voltage
GND	2	ground
DRIVER	3	gate driver output
SOURCE	4	current sense input
VINSENSE	5	input voltage protection input
PROTECT	6	general-purpose protection input
CTRL	7	control input
OPTIMER	8	overpower and restart timer

8. Functional description

8.1 Introduction

The SSL5001T is a buck-boost and flyback driver for small form factor retrofit SSL lamps and separate LED drivers.

8.2 Converter operation

The converter in the SSL5001T is a low-cost fixed frequency, peak current controlled system. See [Figure 3](#) for the basic application diagram. See [Figure 5](#) for the waveforms. To reduce ElectroMagnetic Interference (EMI), frequency jitter has been implemented.

Energy is stored in inductor L each period that the switch is on. The inductor current I_L is zero when the MOSFET is switched on. The amplitude of the current build-up in L is proportional to the voltage difference across the inductor and the time that the MOSFET switch is on.

When the MOSFET is switched off, the current continues to flow through the output diode. The current then falls at a rate proportional to the value of V_{OUT} and the flyback transformer winding ratio.

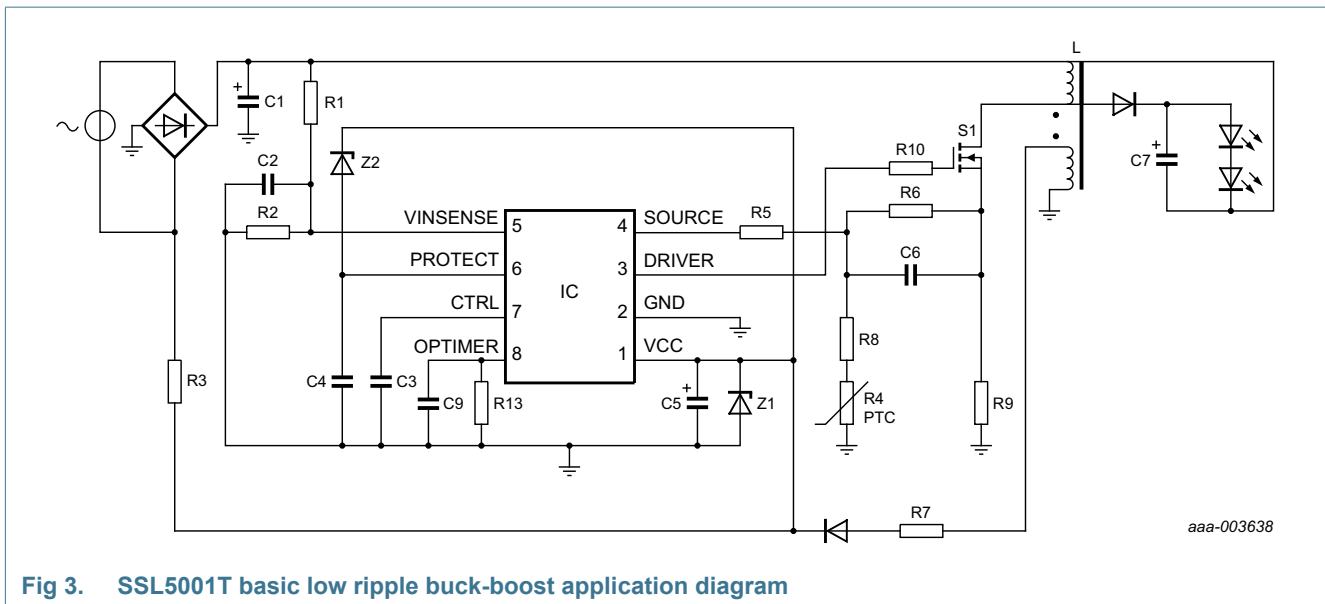

Fig 3. SSL5001T basic low ripple buck-boost application diagram

8.3 Conversion frequency

The SSL5001T is operating in the Fixed frequency mode. The inductance value has no influence on the operating frequency. The maximum inductance applicable is determined by the operating point (71 kHz) at which DCM operation can be guaranteed.

8.4 DRIVER pin

The SSL5001T is equipped with a driver that can control an external MOSFET switch. The voltage on the driver output pin is increased towards $V_{O(DRIVER)max}$ to open the switch during the first cycle (t_0 to t_1). The voltage on the driver output pin is pulled down towards a low level from the start of the secondary stroke until the next cycle starts (t_0 to t_{00}).

The driver circuit to the power MOSFET gate has a current sourcing capability of 300 mA and a current sink capability of 750 mA. This enables efficient operation due to the fast power MOSFET switch-on and switch-off.

At the lowest VCC voltage ($V_{CC(stop)}$), the voltage of the driver is $V_{O(DRIVER)min}$.

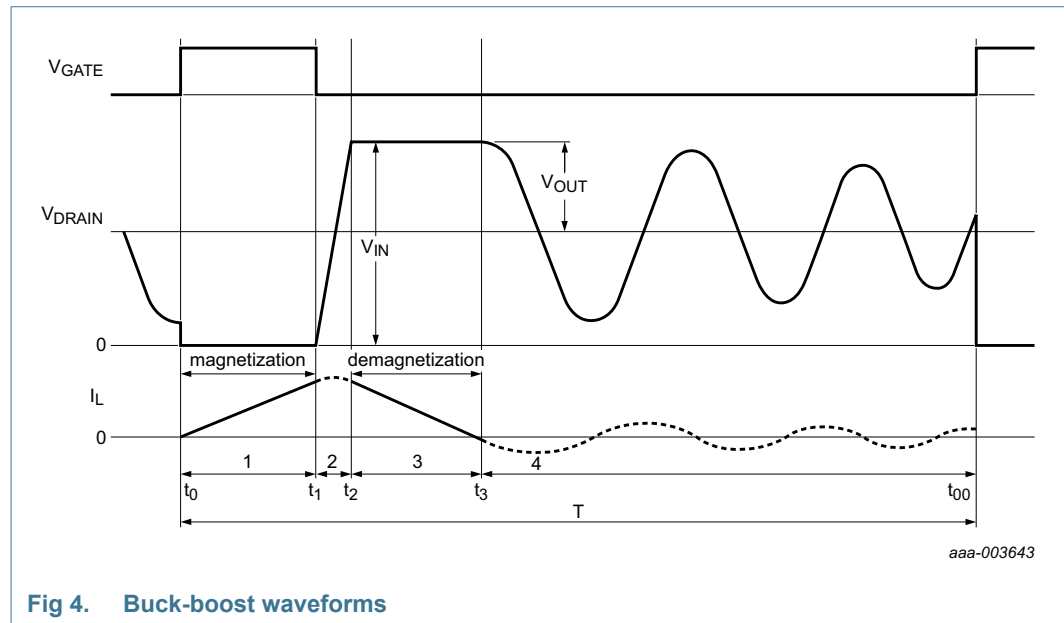

Fig 4. Buck-boost waveforms

8.5 Protective features

The IC has the following protections:

- UnderVoltage LockOut (UVLO)
- Output OverVoltage Protection (OVP)
- Leading Edge Blanking (LEB)
- OverCurrent Protection (OCP)
- Internal OverTemperature Protection (OTP)
- Mains UnderVoltage Protection (UVP) and OverVoltage Protection (OVP)
- Output Short Protection (OSP)

The internal OTP is a latched protection. This protective feature causes the IC to halt until a reset (a result of power cycling) is executed. When V_{CC} drops lower than $V_{CC(rst)}$, the IC resets the latch protection mode. Switching starts only when no fault condition exists.

8.5.1 UnderVoltage LockOut (UVLO)

When the voltage on the VCC pin drops lower than $V_{CC(stop)}$, the IC stops switching. A restart attempt is made after the external resistor fully recharges the VCC capacitor. At an output short-circuit the auxiliary voltage is reduced significantly, depending on the coupling of the transformer. As a result the UVLO is activated providing an adequate short-circuit protection.

8.5.2 Leading Edge Blanking (LEB)

To prevent false detection of overcurrent, a blanking time following switch-on is implemented. When the MOSFET switch turns on there can be a short current spike due to capacitive discharge of voltage over the drain and source. During the LEB time (t_{leb}), the spike is disregarded.

8.5.3 OverCurrent Protection (OCP)

The SSL5001T contains a peak current detector. It triggers when the voltage at the SOURCE pin reaches the peak-level $V_{th(ocp)SOURCE}$. The current through the switch is sensed using a resistor connected to the SOURCE pin. The sense circuit is activated following LEB time t_{leb} . There is a propagation delay between overcurrent detection and the actual closure of the switch $t_{d(ocp-swoff)}$. Due to the delay, the actual peak current is slightly higher than the OCP level set using the resistor in series to the SOURCE pin. This effect can be compensated by the mains overpower compensation as described in [Section 8.5.6](#).

8.5.4 OverTemperature Protection (OTP)

When the internal OTP function is triggered at a certain IC temperature ($T_{th(act)otp}$), the converter stops operating. OTP is a latched protection which is reset by removing the voltage from the VCC pin.

8.5.5 Mains UnderVoltage Protection (UVP)

Mains undervoltage protection is designed to limit the lamp power when the input voltage drops too low. Since the input power has to remain constant, the input current would otherwise increase to a level that is too large for the input circuitry.

8.5.6 Mains OverPower Compensation (OPC)

The overpower compensation function can be used to realize a maximum output power which is nearly constant over the full mains input. The overpower compensation circuit measures the input voltage on the VINSENSE pin and outputs a proportionally dependent current on the SOURCE pin (see [Figure 5](#)). The DC voltage across the soft-start resistor limits the maximum peak current on the current sense resistor.

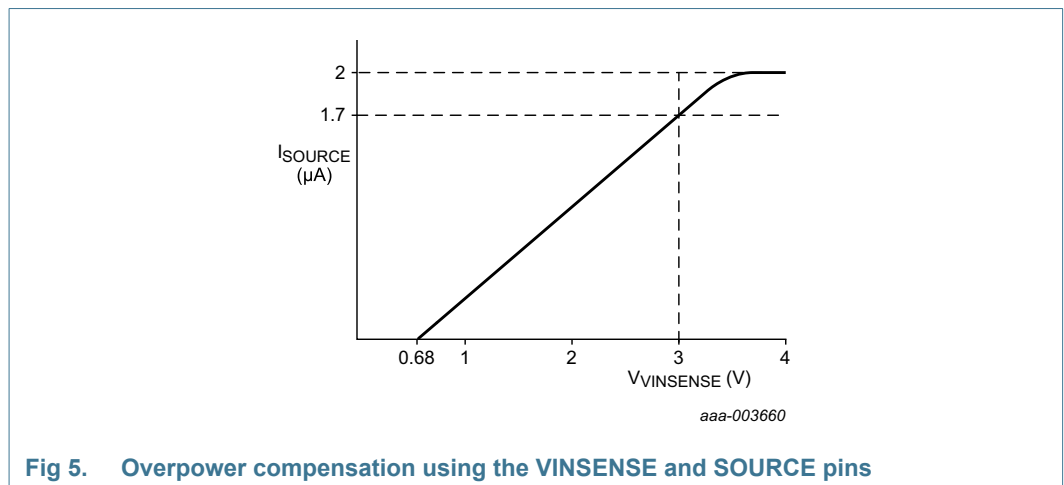

Fig 5. Overpower compensation using the VINSENSE and SOURCE pins

8.5.7 Protection input (PROTECT PIN)

The PROTECT pin is a general-purpose input which can be used to switch off the converter (latched protection). The converter is stopped when the voltage on this pin is pulled above $V_{\text{det(H)}(\text{PROTECT})}$ (0.8 V) or under $V_{\text{det(L)}(\text{PROTECT})}$ (0.5 V). A current of 32 μA flows from the IC when V_{PROTECT} is at $V_{\text{det(L)}(\text{PROTECT})}$. A current of 107 μA flows into the IC, when V_{PROTECT} is at $V_{\text{det(H)}(\text{PROTECT})}$ level.

The PROTECT input can be used to create overvoltage detection and OTP functions. Connect a 22 nF capacitor in parallel to a 1 M Ω resistor to the PROTECT pin if the protective features of this pin are not used.

An internal 4.1 V clamp protects this pin from overvoltage situations.

8.6 VCC supply

The SSL5001T can be supplied using three methods:

- Under normal operation, the voltage on the auxiliary winding is rectified and generates the V_{CC} supply voltage
- At start-up, an external resistor provides internal power until either the auxiliary supply or an external current on the VCC pin provides the supply
- An external voltage source can be connected to the VCC pin

Initially, the capacitor on the VCC pin is charged from the high-voltage mains via resistor R3.

If V_{CC} is lower than V_{startup} , the IC current consumption is low (10 μA). When V_{CC} reaches V_{startup} , the IC first waits for the VINSENSE pin to reach $V_{\text{start(VINSENSE)}}$ and the PROTECT pin to reach $V_{\text{det(L)}(\text{PROTECT})}$. When both levels are reached, the IC charges the SOURCE pin to the $V_{\text{start(soft)}}$ level and starts switching. In a typical application, the supply voltage is taken over by the auxiliary winding of the transformer.

If a protection is triggered, the controller stops switching. Depending on the triggered protection, a restart or latch to an off-state is activated.

A restart caused by a protection rapidly charges the OPTIMER pin to 4.5 V. The IC enters Power-down mode until the OPTIMER pin discharges to 1.2 V. In Power-down mode, the IC consumes a very low supply current (10 μA) and the VCC pin is clamped at 22 V using an internal clamp circuit. When the voltage on the OPTIMER pin drops under 1.2 V and the VCC pin voltage is higher than the VCC start-up voltage (see [Figure 4](#)), the IC restarts. Connect a 180 k Ω resistor between the OPTIMER pin and the ground for proper operation. The parallel capacitor can be chosen freely to set the desired hiccup frequency.

When a latched protection is triggered, the IC immediately enters Power-down mode. The VCC pin is clamped to a voltage just above the latch protection reset voltage ($V_{\text{rst(latch)}} + 1 \text{ V}$).

When the voltage on the VCC pin drops under $V_{\text{th(UVLO)}}$ during normal operation, the controller stops switching and enters restart mode. In restart mode, the driver output is disabled and the VCC pin voltage is recharged using resistor R3 which is connected to the rectified mains.

Remark: The V_{CC} clamp current of the IC is $240\ \mu\text{A}$. As a result an external 30 V Zener clamp can be required in applications with a short start-up time.

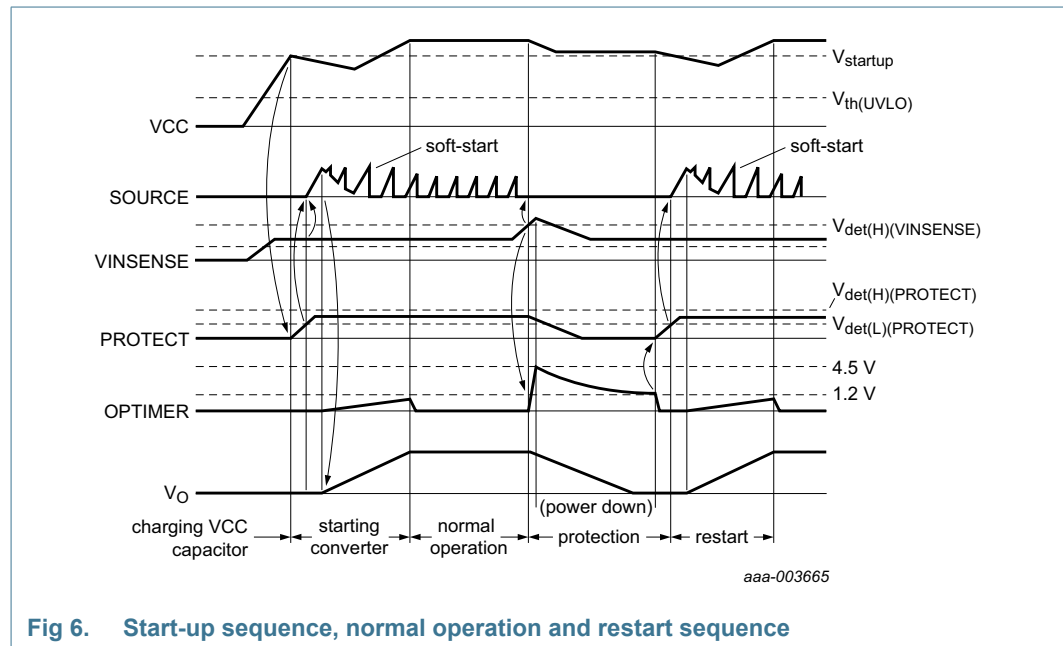

Fig 6. Start-up sequence, normal operation and restart sequence

8.7 Supply management

All internal reference voltages are derived from a temperature compensated on-chip band gap circuit. The internal reference currents are derived from a trimmed and temperature compensated current reference circuit.

8.8 Soft-start function

To prevent audible noise during start-up or a restart condition, a soft-start is made. Before the converter starts, the soft-start capacitor (C6, see [Figure 9](#)) on the SOURCE pin is charged. When the converter starts switching, the primary peak current slowly increases as the soft-start capacitor discharges through the soft-start resistor (R6, see [Figure 9](#)). The soft-start capacitor value selected sets the soft-start time constant. The soft-start resistor value must also be taken into account but overpower compensation typically defines this value (see [Section 8.5.5](#)). The soft-start resistor R5 must be at least $12\ \text{k}\Omega$ to ensure a proper start-up.

8.9 Input voltage detection (VINSENSE pin)

In a typical application, the mains input voltage can be detected by the VINSENSE pin. Switching does not take place until the voltage on VINSENSE has reached $V_{start(VINSENSE)}$ (0.94 V).

When the VINSENSE voltage drops under $V_{det(L)(VINSENSE)}$ (0.72 V) or exceeds $V_{det(H)(VINSENSE)}$ (3.52 V), the converter stops switching and performs a restart.

If pin VINSENSE is left open or disconnected, the pin is pulled up by the internal 20 nA current source to reach the $V_{det(H)(VINSENSE)}$ level. This triggers restart protection. An internal 5.2 V clamp protects the VINSENSE pin from overvoltages.

8.10 Duty cycle control (CTRL pin)

The output power of the converter is regulated by the CTRL pin. This pin is connected to an internal 5.4 V supply using an internal 7 kΩ resistor.

The CTRL pin voltage sets the peak current which is measured using the SOURCE pin (see Section 8.11). At a low output power, the switching frequency is also reduced. The maximum duty cycle is limited to 72 %.

8.11 Current mode control (SOURCE pin)

Current mode control is used for its good line regulation.

The primary current is sensed by the SOURCE pin across an external resistor R9 (see Figure 9) and compared with an internal reference voltage. The internal reference voltage is proportional to the CTRL pin voltage (see Figure 7).

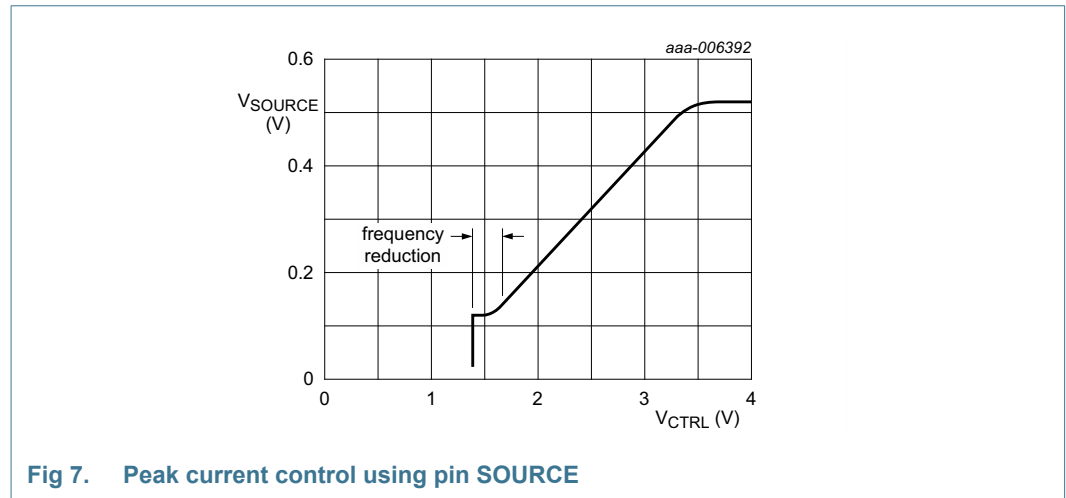

Fig 7. Peak current control using pin SOURCE

Leading edge blanking prevents false triggering due to capacitive discharge when switching on the external power switch (see Figure 8).

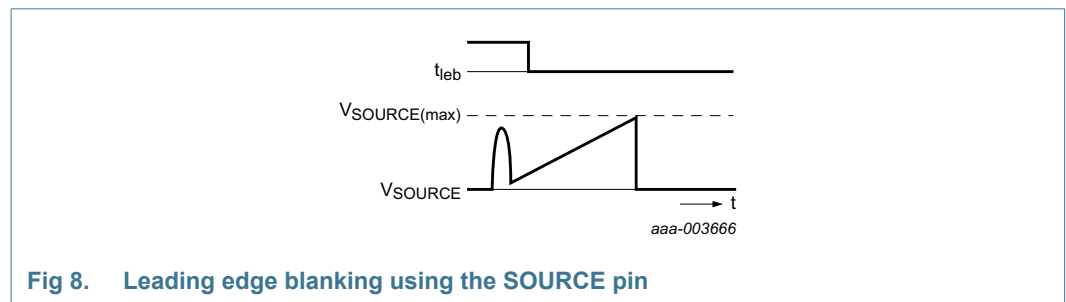

Fig 8. Leading edge blanking using the SOURCE pin

9. Limiting values

Table 4. Limiting values

In accordance with the Absolute Maximum Rating System (IEC 60134).

Symbol	Parameter	Conditions	Min	Max	Unit
Voltages					
V _{CC}	supply voltage	continuous	-0.4	+30	V
		t < 100 ms	-	35	V
V _{VINSENSE}	voltage on pin VINSENSE	current limited	-0.4	+5.5	V
V _{PROTECT}	voltage on pin PROTECT	current limited	-0.4	+5	V
V _{CTRL}	voltage on pin CTRL		-0.4	+5.5	V
V _{IO(OPTIMER)}	input/output voltage on pin OPTIMER		-0.4	+5	V
V _{SOURCE}	voltage on pin SOURCE	current limited	-0.4	+5	V
Currents					
I _{CC}	supply current	pin VCC; $\delta < 10\%$	-	+0.4	A
I _{I(VINSENSE)}	input current on pin VINSENSE		-1	+1	mA
I _{I(PROTECT)}	input current on pin PROTECT		-1	+1	mA
I _{CTRL}	current on pin CTRL		-3	0	mA
I _{SOURCE}	current on pin SOURCE		-10	+1	mA
I _{DRIVER}	current on pin DRIVER	$\delta < 10\%$	-0.4	+1	A
General					
P _{tot}	total power dissipation	T _{amb} < 75 °C	-	0.5	W
T _{stg}	storage temperature		-55	+150	°C
T _j	junction temperature		-40	+150	°C
T _{amb}	ambient temperature		<tbd>	<tbd>	°C

Table 4. Limiting values ...continued
 In accordance with the Absolute Maximum Rating System (IEC 60134).

Symbol	Parameter	Conditions	Min	Max	Unit
ESD					
V _{ESD}	electrostatic discharge voltage	class 1			
		human body model [1]	-	4000	V
		machine model [2]	-	300	V
		charged device model	-	750	V

[1] Equivalent to discharging a 100 pF capacitor through a 1.5 k Ω series resistor.

[2] Equivalent to discharging a 200 pF capacitor through a 0.75 μ H coil and a 10 Ω resistor.

10. Thermal characteristics

Table 5. Thermal characteristics

Symbol	Parameter	Conditions	Typ	Unit
R _{th(j-a)}	thermal resistance from junction to ambient	in free air; JEDEC test board	150	K/W
R _{th(j-c)}	thermal resistance from junction to case	in free air; JEDEC test board	79	K/W

11. Characteristics

Table 6. Characteristics

$T_{amb} = 25\text{ }^{\circ}\text{C}$; $V_{CC} = 20\text{ V}$; all voltages are measured with respect to ground (pin 2); currents are positive when flowing into the IC; unless otherwise specified.

Symbol	Parameter	Conditions	Min	Typ	Max	Unit
Supply voltage management (VCC pin)						
V _{startup}	start-up voltage		18.6	20.6	22.6	V
V _{th(UVLO)}	undervoltage lockout threshold voltage		11.2	12.2	13.2	V
V _{clamp(VCC)}	clamp voltage on pin VCC	activated during restart	-	V _{startup} + 1	-	V
		activated during latched protection	-	V _{rst(latch)} + 1	-	V
V _{hys}	hysteresis voltage	V _{startup} - V _{th(UVLO)}	8	9	10	V
I _{CC(startup)}	start-up supply current	V _{CC} < V _{startup}	5	10	15	μ A
I _{CC}	supply current	no load on pin DRIVER	0.4	0.5	0.6	mA
V _{rst(latch)}	latched reset voltage		4	5	6	V

Table 6. Characteristics ...continued

$T_{amb} = 25\text{ }^{\circ}\text{C}$; $V_{CC} = 20\text{ V}$; all voltages are measured with respect to ground (pin 2); currents are positive when flowing into the IC; unless otherwise specified.

Symbol	Parameter	Conditions	Min	Typ	Max	Unit
Input voltage sensing (VINSENSE pin)						
$V_{start}(VINSENSE)$	start voltage on pin VINSENSE	detection level	0.89	0.94	0.99	V
$V_{det(L)}(VINSENSE)$	LOW-level detection voltage on pin VINSENSE		0.68	0.72	0.76	V
$V_{det(H)}(VINSENSE)$	HIGH-level detection voltage on pin VINSENSE		3.39	3.52	3.65	V
$I_{O}(VINSENSE)$	output current on pin VINSENSE		-	-20	-	nA
$V_{clamp}(VINSENSE)$	clamp voltage on pin VINSENSE	$I_{I}(VINSENSE) = 50\text{ }\mu\text{A}$	-	5.2	-	V
Protection input (PROTECT pin)						
$V_{det(L)}(PROTECT)$	LOW-level detection voltage on pin PROTECT		0.47	0.50	0.53	V
$V_{det(H)}(PROTECT)$	HIGH-level detection voltage on pin PROTECT		0.75	0.8	0.85	V
$I_{O}(PROTECT)$	output current on pin PROTECT	$V_{PROTECT} = V_{low}(PROTECT)$	-34	-32	-30	μA
		$V_{PROTECT} = V_{high}(PROTECT)$	87	107	127	μA
$V_{clamp}(PROTECT)$	clamp voltage on pin PROTECT	$I_{I}(PROTECT) = 200\text{ }\mu\text{A}$ [1]	3.5	4.1	4.7	V
Peak current control (CTRL pin)						
V_{CTRL}	voltage on pin CTRL	for minimum flyback peak current	1.5	1.8	2.1	V
		for maximum flyback peak current	3.4	3.9	4.3	V
$R_{int}(CTRL)$	internal resistance on pin CTRL		5	7	9	k Ω
$I_{O}(CTRL)$	output current on pin CTRL	$V_{CTRL} = 1.4\text{ V}$	-0.7	-0.5	-0.3	mA
		$V_{CTRL} = 3.7\text{ V}$	-0.28	-0.2	-0.12	mA
Pulse width modulator						
f_{osc}	oscillator frequency		62	66.5	71	kHz
f_{mod}	modulation frequency		210	280	350	Hz
Δf_{mod}	modulation frequency variation		± 3	± 4	± 5	kHz

Table 6. Characteristics ...continued

$T_{amb} = 25\text{ }^{\circ}\text{C}$; $V_{CC} = 20\text{ V}$; all voltages are measured with respect to ground (pin 2); currents are positive when flowing into the IC; unless otherwise specified.

Symbol	Parameter	Conditions	Min	Typ	Max	Unit
δ_{max}	maximum duty cycle		68.5	72	79	%
$V_{start(red)f}$	frequency reduction start voltage	CTRL pin	1.5	1.8	2.1	V
$V_{\delta(zero)}$	zero duty cycle voltage	CTRL pin	1.25	1.55	1.85	V
Overpower protection (OPTIMER pin)						
$V_{prot(OPTIMER)}$	protection voltage on pin OPTIMER		2.4	2.5	2.6	V
$I_{prot(OPTIMER)}$	protection current on pin OPTIMER	no overpower situation	100	150	200	μA
		overpower situation	-12.2	-10.7	-9.2	μA
Restart timer (OPTIMER pin)						
$V_{restart(OPTIMER)}$	restart voltage on pin OPTIMER	low-level	0.8	1.2	1.6	V
		high-level	4.1	4.5	4.9	V
$I_{restart(OPTIMER)}$	restart current on pin OPTIMER	charging OPTIMER capacitor	-127	-107	-87	μA
		discharging OPTIMER capacitor	-0.1	0	0.1	μA
Current sense (SOURCE pin)						
$V_{SOURCE(max)}$	maximum voltage on pin SOURCE	$\Delta V/\Delta t = 50\text{ mV}/\mu\text{s}$; $V_{VINSENSE} = 0.78\text{ V}$	0.48	0.51	0.54	V
		$\Delta V/\Delta t = 200\text{ mV}/\mu\text{s}$; $V_{VINSENSE} = 0.78\text{ V}$	0.50	0.53	0.56	V
$V_{th(opp)SOURCE}$	overpower protection threshold voltage on pin SOURCE		370	400	430	mV
$\Delta V_{sc}/\Delta t$	slope compensation voltage	pin SOURCE; $\Delta V/\Delta t = 50\text{ mV}/\mu\text{s}$	17	25	33	$\text{mV}/\mu\text{s}$
t_{leb}	leading edge blanking time		250	300	350	ns
Overpower compensation (VINSENSE and SOURCE pins)						
$I_{opc(SOURCE)}$	overpower compensation current on pin SOURCE	$V_{VINSENSE} = 1.25\text{ V}$; $V_{SOURCE(max)} > 400\text{ mV}$	-1.0	-	+0.1	μA
		$V_{VINSENSE} = 2.75\text{ V}$; $V_{SOURCE(max)} > 400\text{ mV}$	-2.6	-	-1.0	μA
		$V_{VINSENSE} = 4\text{ V}$; $V_{SOURCE(max)} > 400\text{ mV}$	-2.2	-	-1.9	μA
Soft-start (SOURCE pin)						
$I_{start(soft)}$	soft start current		-63	-55	-47	μA
$V_{start(soft)}$	soft start voltage	$V_{CTRL} = 4\text{ V}$; enable voltage	-	$V_{sense(max)}$	-	V

Table 6. Characteristics ...continued

$T_{amb} = 25\text{ }^{\circ}\text{C}$; $V_{CC} = 20\text{ V}$; all voltages are measured with respect to ground (pin 2); currents are positive when flowing into the IC; unless otherwise specified.

Symbol	Parameter	Conditions	Min	Typ	Max	Unit
$R_{start(soft)}$	soft start resistance		12	-	-	k Ω
Driver (DRIVER (pin))						
$I_{source(DRIVER)}$	source current on pin DRIVER	$V_{DRIVER} = 2\text{ V}$	-	-0.3	-0.25	A
$I_{sink(DRIVER)}$	sink current on pin DRIVER	$V_{DRIVER} = 2\text{ V}$	0.25	0.3	-	A
		$V_{DRIVER} = 10\text{ V}$	0.6	0.75	-	A
$V_{O(DRIVER)max}$	maximum output voltage on pin DRIVER	$V_{CC} > V_{CC(startup)}$	9	10.5	12	V
Temperature protection						
$T_{pl(IC)}$	IC protection level temperature	latching	130	140	150	$^{\circ}\text{C}$

[1] The clamp voltage on the PROTECT pin is lowered when the IC is in power-down (latched or restart protection).

12. Application information

A LED driver with the SSL5001T is a flyback converter operating in Discontinuous Conduction Mode (DCM) and if required in Continuous Conduction Mode (CCM) (See [Figure 9](#)).

Capacitor C5 buffers the IC supply voltage, which is powered using resistor R3 at start-up and using the auxiliary winding during normal operation. Sense resistor R9 converts the current through the MOSFET S1 into a voltage on the SOURCE pin. The value of R9 defines the maximum primary peak current on MOSFET S1. Resistor R7 reduces the peak current to capacitor C5.

In the example shown in [Figure 9](#), the OTP level is set by Positive Temperature Coefficient (PTC) resistor R4. The VINSENSE pin is used for mains voltage detection and resistors R1 and R2 set the start voltage to about 80 V (AC).

Resistor R6 and capacitor C6 define the soft-start time. Resistor R5 prevents the soft-start capacitor C6 from being charged during normal operation caused by negative voltage spikes across the current sense resistor R9.

Capacitor C3 reduces noise on the CTRL pin.

The approximate output power to the LEDs (DCM mode) can be calculated with [Equation 1](#):

$$P_{LED} = \eta \times \frac{I}{2} \times L_{prim} \times \left(\frac{V_{SOURCE(max)}}{R9} \right)^2 \times f_{osc} \tag{1}$$

Where:

- η is the expected frequency.

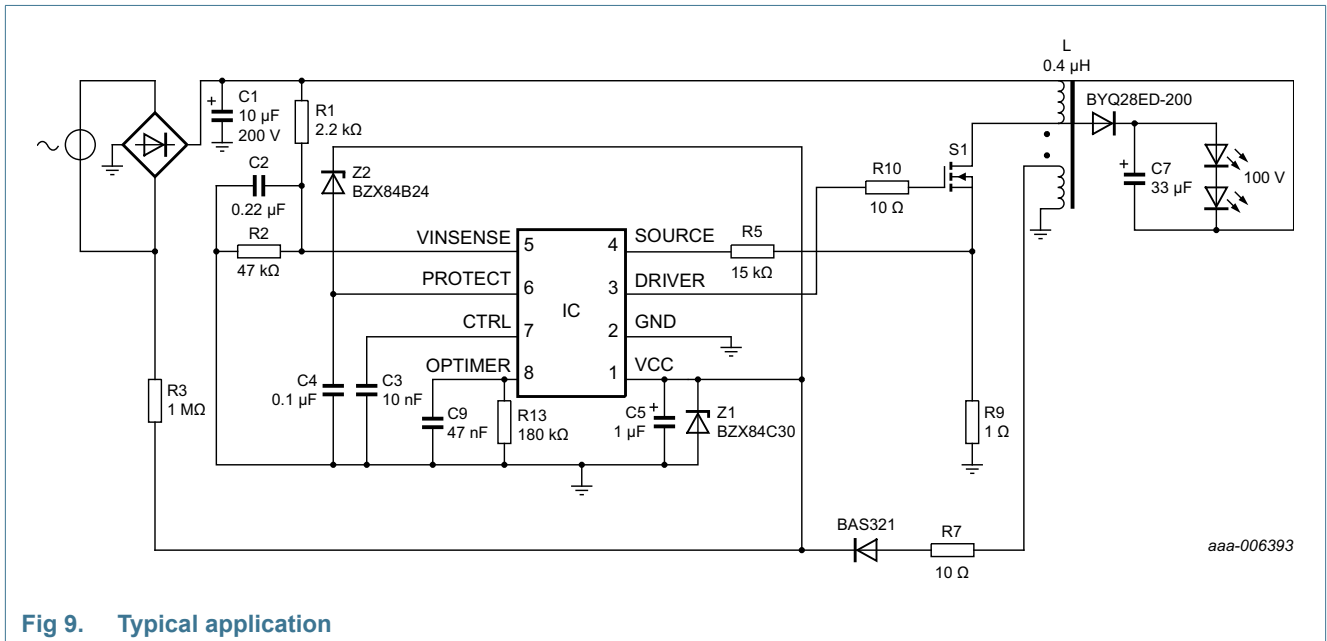

Fig 9. Typical application

13. Package outline

SO8: plastic small outline package; 8 leads; body width 3.9 mm

SOT96-1

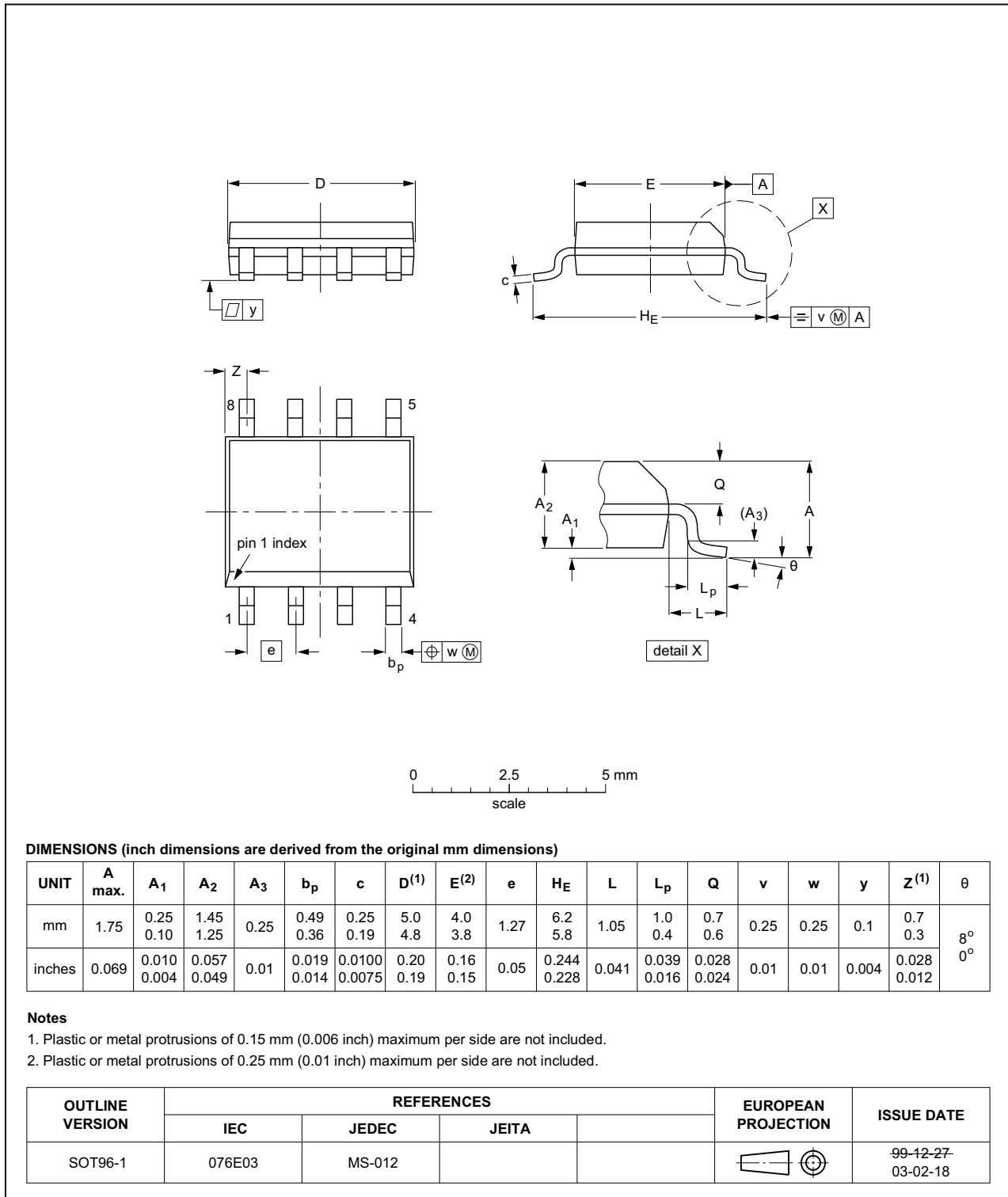

Fig 10. Package outline SOT96-1 (SOT8)