



SILERGY

# SY2A27352

## 300mA, 36V Fast-Response LDO Regulator with Reset Output

### General Description

The SY2A27352 is an automotive grade, 300mA high-current capacity linear regulator with ultra-low ground current and low drop-out voltage. The device offers protective features, including an over-current limit, output short protection, and over-temperature protection. The SY2A27352 has an adjustable output that can be configured using two external resistors.

The device offers an open-drain, active low reset output which can be used to hold a microcontroller in reset until the input voltage is above the preconfigured threshold. The reset duration can be adjusted using an optional, external capacitor.

The SY2A27352 is available in a compact SO8E package.

### Features

- Wide Input Voltage Range: 4V to 36V
- Adjustable Output Voltage
- Low-Dropout Voltage: 300mV at Full Load 300mA
- High-Current Capability: 300mA Over Full Temperature Range
- Low Ground Current
- Over-Current Limit Protection
- Output Short Circuit Protection (Hiccup Mode)
- Over-Temperature Protection
- Reset Output with Programmable Timeout Period
- Package: SO8E
- RoHS Compliant and Halogen Free
- Automotive AEC- Q100 Grade 1 Qualified

### Applications

- Industrial/Automotive Applications
- Portable/Battery-Powered Equipment
- Ultra-Low-Power Microcontrollers
- Cellular Handsets
- Medical Imaging

### Typical Application

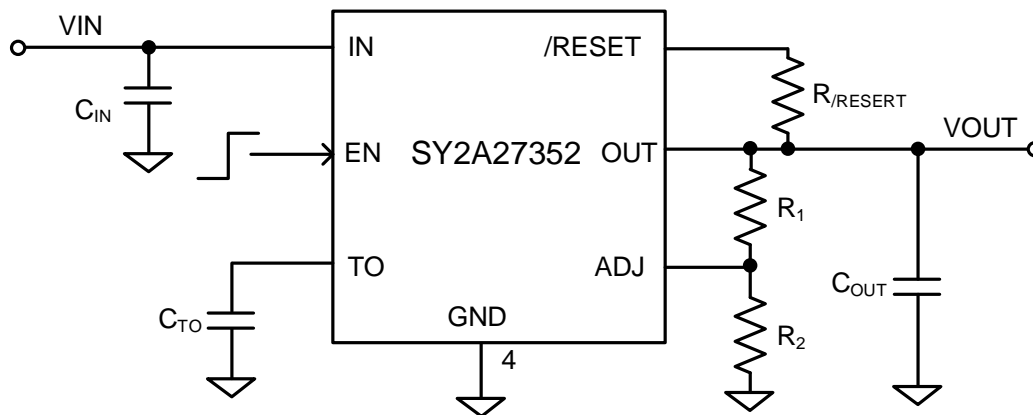

Figure 1. Typical Application Schematic

## Ordering Information

Ordering Part Number	Package Type	Top Mark
SY2A27352FCA	SO8E RoHS Compliant and Halogen Free	<b>BTExyz</b>

*x=year code, y=week code, z= lot number code*

## Pinout (top view)

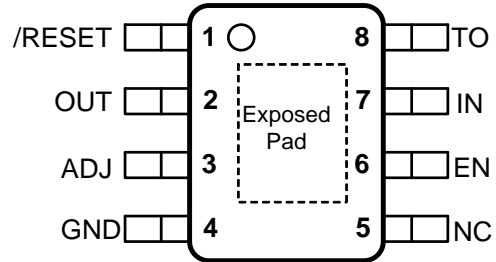

Pin Name	Pin Number	Pin Description
/RESET	1	Open drain reset output. /RESET low when OUT is below the reset threshold and remains low for the reset timeout period after the reset conditions end. If no capacitor connects at the TO pin, RESET pulls high immediately after $V_{OUT}$ exceeds the reset threshold. If it isn't used, leave it floating or connect to GND.
OUT	2	Output pin. Bypass this pin to the ground pin with a 4.7 $\mu$ F output capacitor.
ADJ	3	Output voltage adjustment pin. Feedback the output voltage through the resistor voltage divider network. $V_{OUT}=0.6 \times (1+R_1/R_2)$ .
GND	4	Ground pin.
NC	5	No connection.
EN	6	Enable pin. Pull it low to shutdown or pull it high to enable; do not leave it floating.
IN	7	Power supply input. Bypass this pin to the ground pin with a 4.7 $\mu$ F capacitor.
TO	8	Reset timeout programming pin. Connect a capacitor from this pin to GND for different reset timeout times.
	Exposed Pad	The exposed pad should be connected to the ground plane for better thermal performance.

## Block Diagram

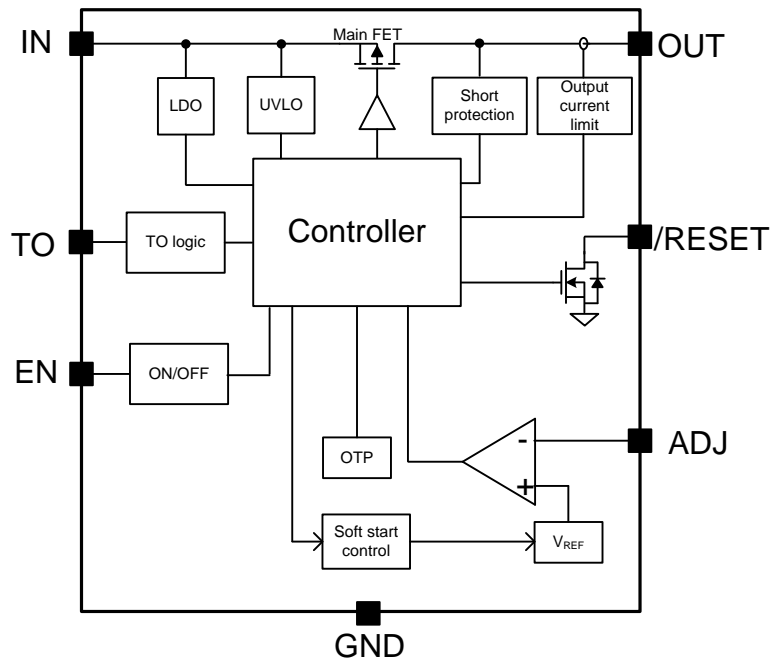

Figure 2. Block Diagram

## Absolute Maximum Ratings

Parameter (Note1)	Min	Max	Unit
IN, EN, OUT, ADJ, /RESET	-0.3	40	V
TO	-0.3	3.6	
Lead Temperature (Soldering, 10 sec.)		260	°C
Junction Temperature, Operating	-40	150	
Storage Temperature	-65	150	

## Thermal Information

Parameter (Note2)	Typ	Unit
$\theta_{JA}$ Junction-to-ambient Thermal Resistance	38.3	°C/W
$\theta_{JC}$ Junction-to-case Thermal Resistance	12.6	
$P_D$ Power Dissipation $T_A = 25^\circ\text{C}$	2.6	W

## Recommended Operating Conditions

Parameter (Note 3)	Min	Max	Unit
IN	4	36	V
EN, OUT, ADJ, /RESET	0	36	
TO	0	3.3	
Ambient Temperature	-40	125	°C



## Electrical Characteristics

( $V_{IN}=V_{EN}=12V$ ,  $T_A=-40^{\circ}C\sim 125^{\circ}C$ , unless otherwise specified, the values are guaranteed by test, design, or statistical correlation)

Parameter	Symbol	Test Conditions	Min	Typical	Max	Unit
Input Voltage	$V_{IN}$		4		36	V
Reference Voltage	$V_{REF}$	$T_A=-40^{\circ}C\sim 125^{\circ}C$	0.588	0.6	0.612	V
		$T_A=25^{\circ}C$	0.594	0.6	0.606	
ADJ pin Bias Current	$I_{ADJ\_Bias}$	$V_{EN}=0V$ , ADJ pin floating	-50		50	nA
Line Regulation	$\Delta V_{LNR}$	$V_{IN}=4V$ to $36V$ , $I_{OUT}=10mA$		1	1.5	mV/V
Load Regulation	$\Delta V_{LDR}$	$V_{IN}=5V$ , $I_{OUT}=10mA$ to $300mA$		0.25	0.5	%
Dropout Voltage	$\Delta V_{DROP}$	$I_{OUT}=10mA$		10	20	mV
		$I_{OUT}=300mA$		300	540	mV
Quiescent Current	$I_Q$	$V_{IN}=(V_{OUT}+1V)$ to $36V$ , $I_{OUT}=0mA$		7	14	$\mu A$
Shutdown Current	$I_{SHDN}$	$V_{EN}=0V$ , $V_{IN}=24V$			5	$\mu A$
Current Limit	$I_{limit}$	$V_{OUT}=0.9*V_{OUT}(\text{normal})$	600	900	1200	mA
Output Short Protection Threshold	$V_{ADJ\_SHORT}$	$V_{FB}$ Falling	8	16	30	% $V_{REF}$
Output Short Off Time	$t_{short\_off}$			16		ms
Power Supply Rejection	PSRR	Frequency=100Hz, $C_{OUT}=4.7\mu F$ , $I_{OUT}=10mA$ , $T_A=25^{\circ}C$		60		dB
		Frequency=100kHz, $C_{OUT}=4.7\mu F$ , $I_{OUT}=10mA$ , $T_A=25^{\circ}C$		35		
Input Voltage UVLO Threshold	$V_{UVLO}$	$V_{IN}$ rising	2.9	3.3	4	V
UVLO Hysteresis	$V_{UVLO\_th}$			200		mV
Enable Input Logic-High Voltage	$V_{EN,H}$		1.5			V
Enable Input Logic-Low Voltage	$V_{EN,L}$				0.4	V
Soft Start Time	$t_{SS}$			1		ms
Thermal Shutdown Temperature	$T_{SD}$			150		$^{\circ}C$
Thermal Shutdown Hysteresis	$T_{HYS}$			20		$^{\circ}C$
$V_{TO}$ /RESET High-level Threshold	$V_{TR}$	$V_{TO}$ rising	1.4	1.8	2.2	V
TO Default Rise Up time	$t_{To,Rise}$	OUT High, TO Floating, TO Rising from 0V to $V_{TR}$		1.6		$\mu s$
TO Charge Current	$I_{TR}$		8	16	24	$\mu A$
$V_{OUT}$ /RESET Threshold	$V_{OR}$	$V_{OUT}$ rising	85	90	95	% $V_{OUT}$
$V_{OUT}$ /RESET Threshold Hysteresis	$V_{OR,HYS}$	$V_{OUT}$ falling		5		% $V_{OUT}$
/RESET Output-Voltage Low					0.4	V



**Note 1:** Stresses beyond "Absolute Maximum Ratings" may cause permanent damage to the device. These are stress ratings only. Functional operation of the device at these or any other conditions beyond those indicated in the operational sections of the specifications is not implied. Exposure to absolute maximum rating conditions for extended periods may affect device reliability.

**Note 2:**  $\theta_{JA}$  is measured in the natural convection at  $T_A = 25^\circ\text{C}$  on a low effective single-layer thermal conductivity test board of JEDEC 51-3 thermal measurement standard.

**Note 3:** The device is not guaranteed to function outside its operating conditions.

## Typical Performance Characteristics

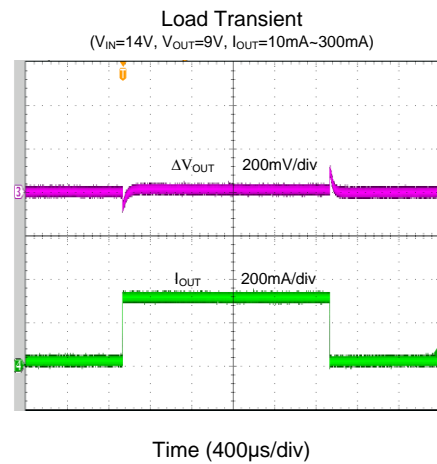
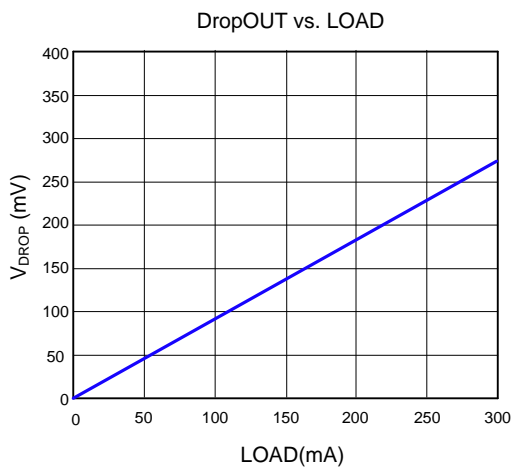
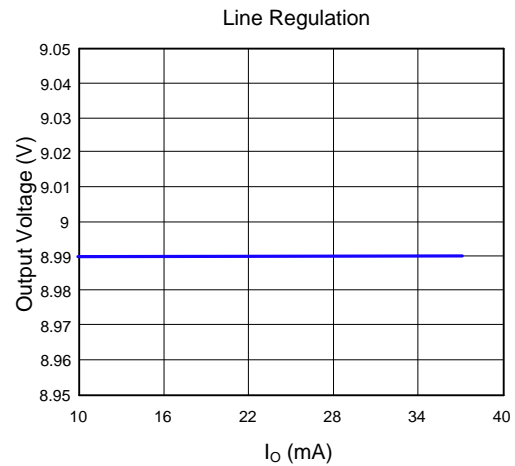
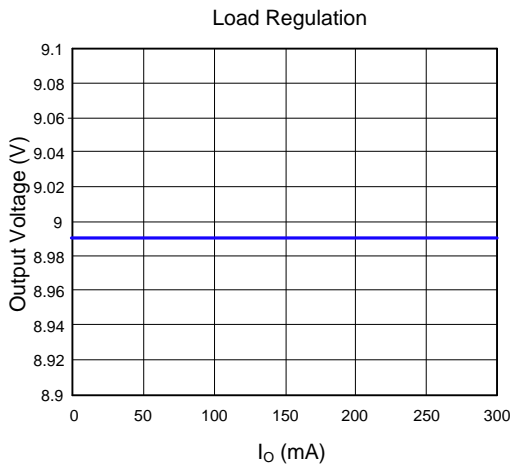
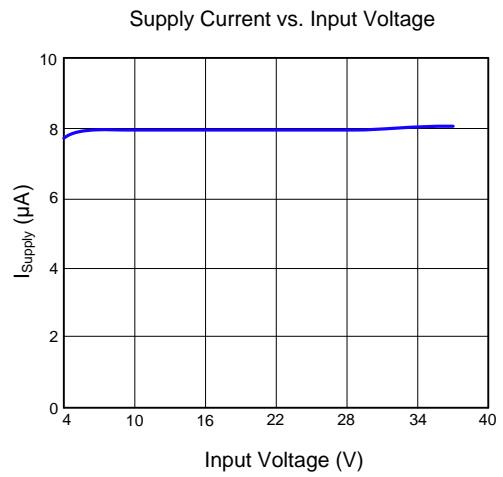
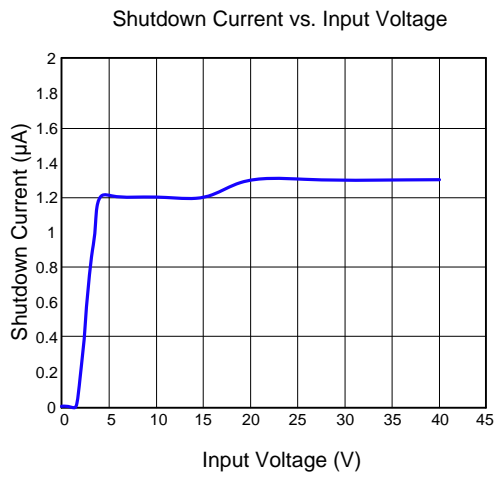

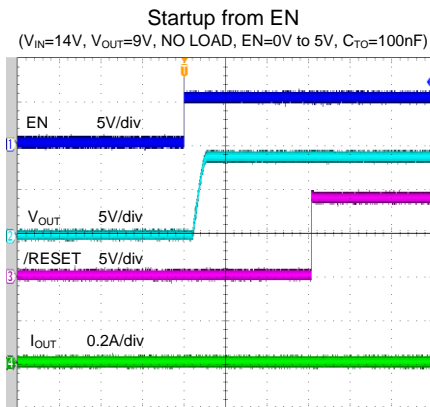

Time (4ms/div)

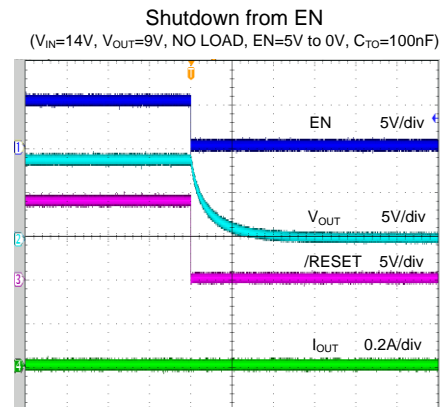

Time (2ms/div)

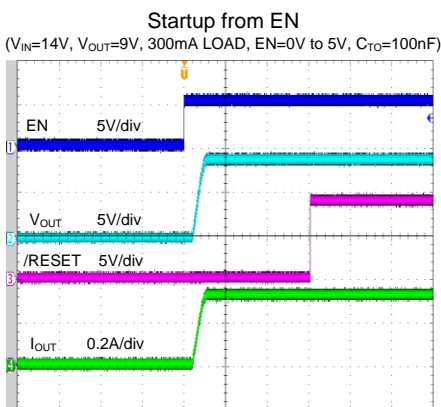

Time (4ms/div)

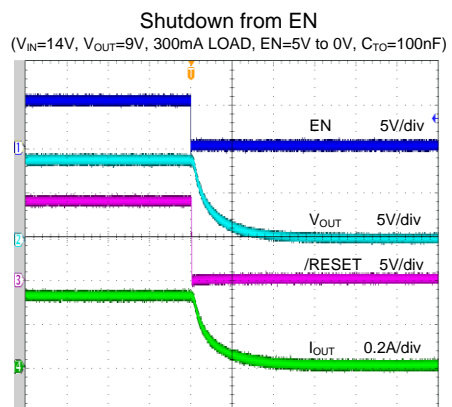

Time (100 $\mu$ s/div)

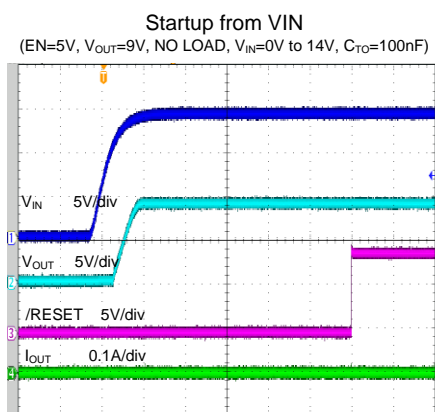

Time (2ms/div)

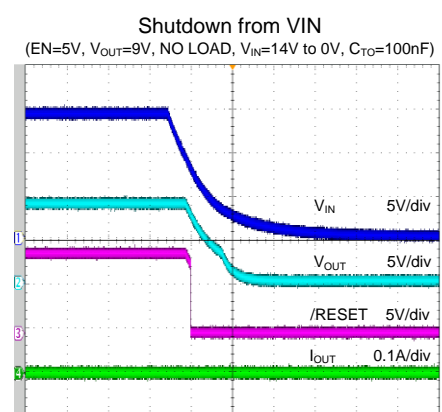

Time (100ms/div)

**Startup from VIN**  
(EN=5V, V<sub>OUT</sub>=9V, 300mA LOAD, V<sub>IN</sub>=0V to 14V, C<sub>TO</sub>=100nF)

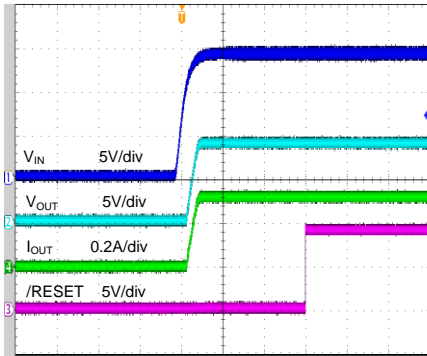

Time (4ms/div)

**Shutdown from VIN**  
(EN=5V, V<sub>OUT</sub>=9V, 300mA LOAD, V<sub>IN</sub>=14V to 0V, C<sub>TO</sub>=100nF)

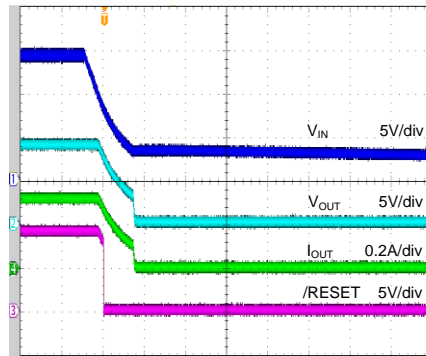

Time (4ms/div)

**Short Protect**  
(VIN=12V, OUT=9V)

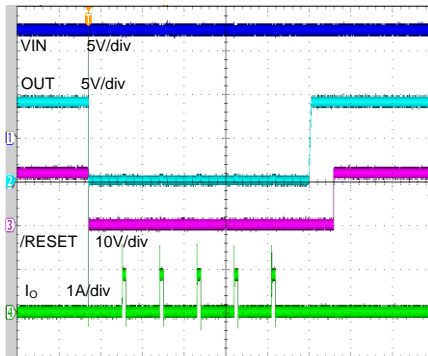

Time (20ms/div)

**LOOP GAIN**

(VIN=12V, OUT=9V, C<sub>OUT</sub>=4.7uF, 300mA Load)  
GAIN Phase

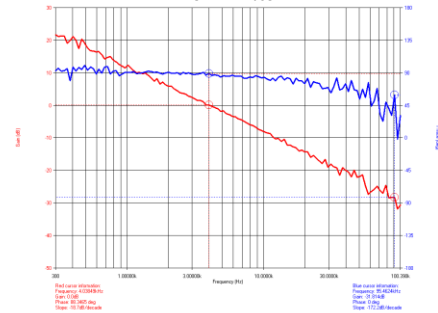

**PSRR**

(VIN=12V, OUT=9V, C<sub>OUT</sub>=4.7uF, 300mA Load)

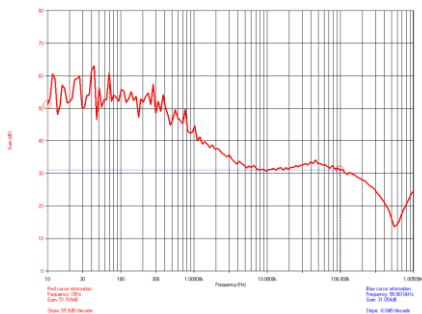



## Application Information

The SY2A27352 is a 300mA high-current capacity linear regulator with ultra-low ground current and low drop-out voltage. The device offers protection features, including an over-current limit, output short and over-temperature protections. The SY2A27352 has an adjustable output that can be configured using two external resistors.

### Adjustable Output Voltage

Choose  $R_1$  and  $R_2$  to program the proper output voltage. To minimize power consumption under light loads, choosing large resistance values for both  $R_1$  and  $R_2$  is recommended. A value of between 10k $\Omega$  and 2M $\Omega$  is highly recommended for both resistors.

The output voltage can be selected using the following equation:

$$V_{OUT} = 0.6V \times (1 + R_1/R_2)$$

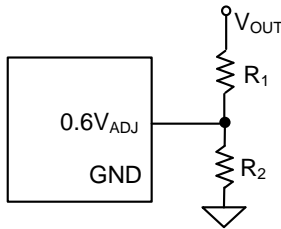

### Over Temperature Protection (OTP)

The SY2A27352 includes over-temperature protection (OTP) circuitry to prevent overheating due to excessive power dissipation. This will turn off the device when the junction temperature exceeds 150°C. Once the junction temperature cools down by approximately 20°C the IC will resume normal operation.

### Output Short Circuit Protect

If  $V_{OUT}$  drops below 16% of the OUT set point, the short circuit protection mode will be initiated, and the device will be shut down for approximately 16ms. The device will then restart with a complete soft-start cycle. If the short circuit condition remains, another 'hiccup' cycle of shutdown and restart will continue indefinitely unless the OTP threshold is reached.

### /RESET Function

The SY2A27352 includes an open-drain reset output. Once the output voltage exceeds the reset threshold voltage (90% of the OUT set point), the  $C_{TO}$  is charged with the current  $I_{TR}$ . /RESET will be in high-impedance state when the voltage on  $C_{TO}$  is larger than  $V_{TR}$ . If the output voltage is lower than the reset threshold voltage, the device discharges  $C_{TO}$  fast, and the /RESET pin is driven to low when the voltage on TO is lower than  $V_{TF}$ .

### Timeout

The SY2A27352 features an adjustable reset timeout period. The internal capacitance produces a 1.6 $\mu$ s default delay when the TO pin is floating. Connect a capacitor from TO to the GND to set a higher timeout period than the default value. Use the following formula to determine the reset timeout capacitor:

$$C_{TO} = \frac{16\mu A \times T_{TIMEOUT}}{1.8V}$$

### Input Capacitor $C_{IN}$ and Output Capacitor $C_{OUT}$

To minimize the switching noise present in the system, improve power-supply rejection (PSRR) and transient response, place a typical X5R or high-grade ceramic capacitor close to the IN and GND pins. Care should be taken to minimize the loop area formed by the  $C_{IN}$  and the IN/GND pins. A 4.7 $\mu$ F ceramic capacitor with a voltage rating 20% higher than the maximum voltage is recommended for most applications.

For stable operation over the full temperature range, a 4.7 $\mu$ F low-ESR ceramic capacitor is recommended for  $C_{OUT}$ . Using larger output-capacitor values such can help with reducing the noise, improve load-transient response and PSRR.

### Example of the Typical Application (3.3V Output)

A typical application circuit with an output of 3.3V is shown below:

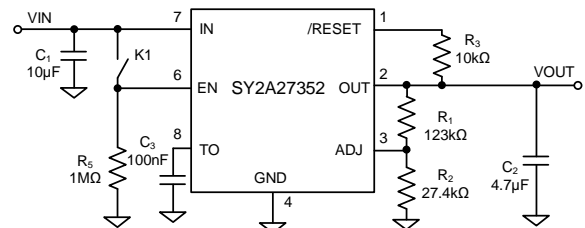

## Application Schematic

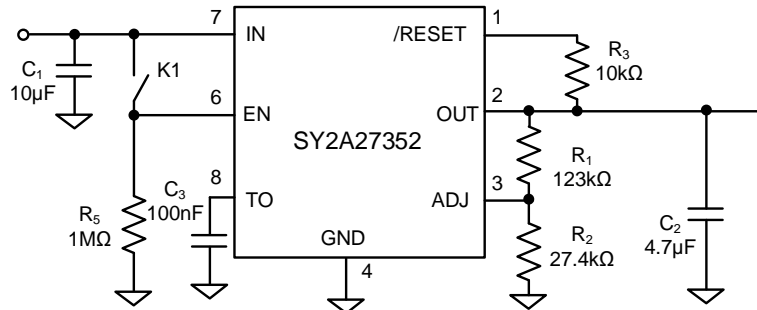

## BOM List

Designator	Description	Part Number	Manufacturer
C <sub>1</sub>	10µF/50V/1206	CL31A106KBHNNNE	SAMSUNG
C <sub>2</sub>	4.7µF/50V/1206	GRM31CR71H475KA12L	MuRata
C <sub>3</sub>	100nF/ 50V// 0603	GRM033R61E104KE14D	MuRata
C <sub>4</sub>	NULL		
R <sub>1</sub>	383kΩ/ 0603 (For 9V OUT)	RC0603FR-07383KL	YAGEO
	124kΩ/ 0603 (For 3.3V OUT)	RC0603FR-07124KL	YAGEO
R <sub>2</sub>	27.4kΩ/ 0603	RC0603FR-0727K4L	YAGEO
R <sub>3</sub>	10kΩ/ 0603	RC0603FR-0710KL	YAGEO
R <sub>5</sub>	100kΩ/ 0603	RC0603FR-07100KL	YAGEO

## PCB Layout Guide

For best performance of the SY2A27352, the following guidelines must be followed:

1. Keep all power traces as short and wide as possible. A 2-layer- or 4-layer board is recommended for improved thermal performance and current flow capability. At least 6 vias are suggested around each power pin to distribute current to different PCB layers. These power pins include IN and OUT.
2. Place the input and output capacitors close to the LDO for better transient performance.
3. Maximize the copper area connected to the exposed pad to improve the heat transfer.

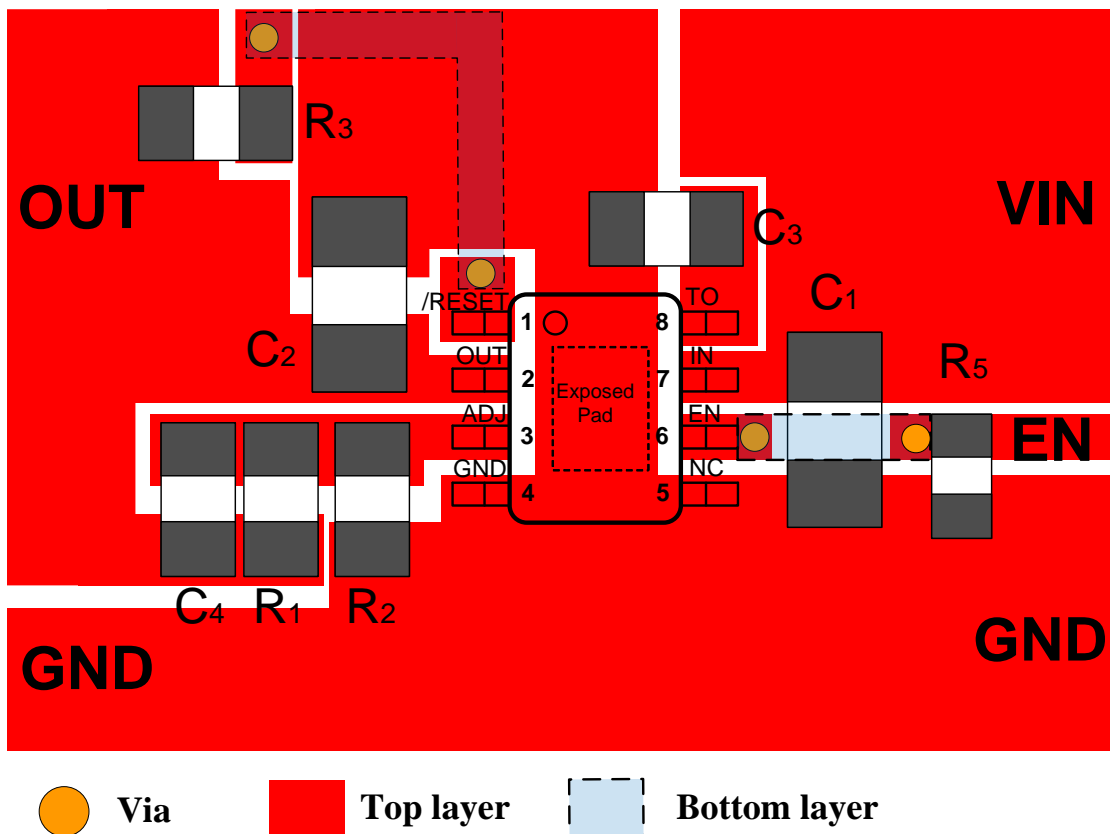
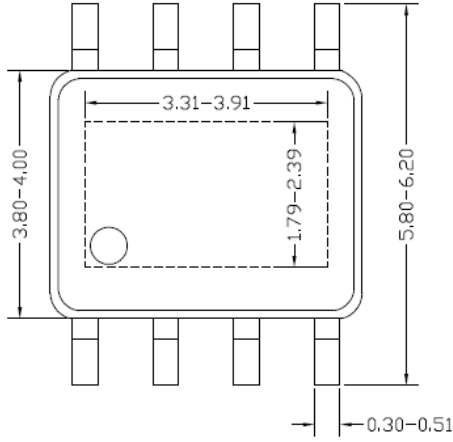
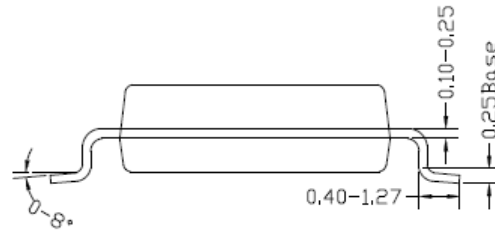

Figure 3. PCB Layout Suggestion

**SO8E Package Outline & PCB Layout**



**Top View**



**Side View**

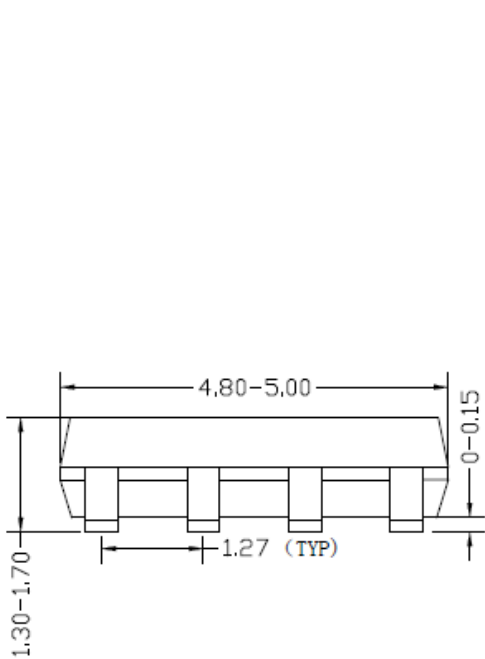

**Front View**

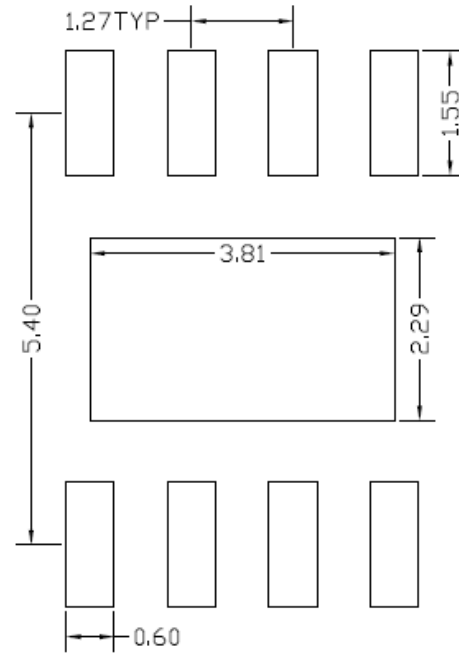

**Recommended PCB Layout  
(Reference Only)**

*Note: All dimensions are in millimeters and exclude mold flash and metal burr.*

## Taping & Reel Specification

### 1. SO8E Taping Orientation

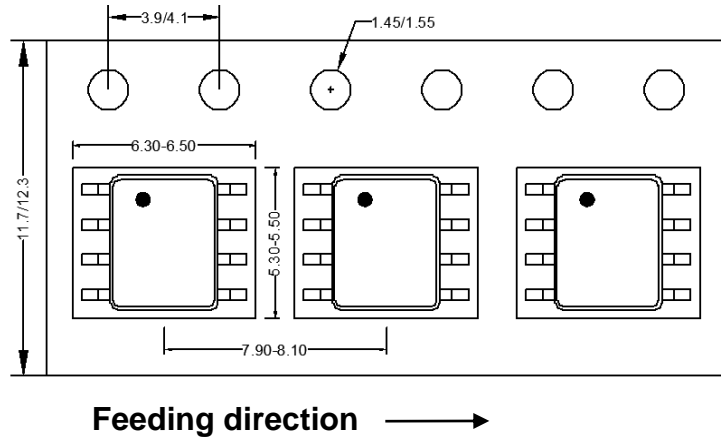

### 2. Carrier Tape & Reel Specification for Packages

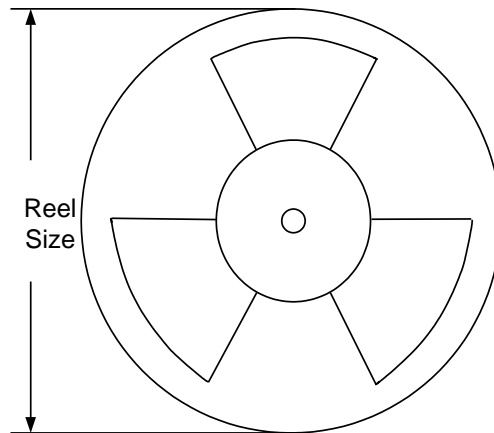

Package types	Tape width (mm)	Pocket pitch(mm)	Reel size (Inch)	Trailer * length(mm)	Leader * length (mm)	Qty per reel (pcs)
SO8E	12	8	13"	400	400	2500

### 3. Others: NA

## Revision History

The revision history provided is for informational purposes only and is believed to be accurate; however, it is not warranted. Please make sure that you have the latest revision.

Date	Revision	Change
Sep.25, 2023	Revision 1.0	Language improvements for clarity.
Apr.13, 2022	Revision 0.9C	Update the Input Voltage UVLO Threshold & Output Short Protection Threshold in EC table (page 4)
Sep.07, 2021	Revision 0.9B	1. Update the package outline drawing.
Jun.12, 2020	Revision 0.9A	1. Update the schematic diagram (page1); 2. Update the startup/shutdown waveforms (page7~8); 3. Update the PCB layout suggestion (page10).
Dec.27, 2019	Revision 0.9	Initial Release

**IMPORTANT NOTICE**

1. **Right to make changes.** Silergy and its subsidiaries (hereafter Silergy) reserve the right to change any information published in this document, including but not limited to circuitry, specification and/or product design, manufacturing or descriptions, at any time and without notice. This document supersedes and replaces all information supplied prior to the publication hereof. Buyers should obtain the latest relevant information before placing orders and should verify that such information is current and complete. All semiconductor products are sold subject to Silergy's standard terms and conditions of sale.

2. **Applications.** Application examples that are described herein for any of these products are for illustrative purposes only. Silergy makes no representation or warranty that such applications will be suitable for the specified use without further testing or modification. Buyers are responsible for the design and operation of their applications and products using Silergy products. Silergy or its subsidiaries assume no liability for any application assistance or designs of customer products. It is customer's sole responsibility to determine whether the Silergy product is suitable and fit for the customer's applications and products planned. To minimize the risks associated with customer's products and applications, customer should provide adequate design and operating safeguards. Customer represents and agrees that it has all the necessary expertise to create and implement safeguards which anticipate dangerous consequences of failures, monitor failures and their consequences, lessen the likelihood of failures that might cause harm and take appropriate remedial actions. Silergy assumes no liability related to any default, damage, costs or problem in the customer's applications or products, or the application or use by customer's third-party buyers. Customer will fully indemnify Silergy, its subsidiaries, and their representatives against any damages arising out of the use of any Silergy components in safety-critical applications. It is also buyers' sole responsibility to warrant and guarantee that any intellectual property rights of a third party are not infringed upon when integrating Silergy products into any application. Silergy assumes no responsibility for any said applications or for any use of any circuitry other than circuitry entirely embodied in a Silergy product.

3. **Limited warranty and liability.** Information furnished by Silergy in this document is believed to be accurate and reliable. However, Silergy makes no representation or warranty, expressed or implied, as to the accuracy or completeness of such information and shall have no liability for the consequences of use of such information. In no event shall Silergy be liable for any indirect, incidental, punitive, special or consequential damages, including but not limited to lost profits, lost savings, business interruption, costs related to the removal or replacement of any products or rework charges, whether or not such damages are based on tort or negligence, warranty, breach of contract or any other legal theory. Notwithstanding any damages that customer might incur for any reason whatsoever, Silergy' aggregate and cumulative liability towards customer for the products described herein shall be limited in accordance with the Standard Terms and Conditions of Sale of Silergy.

4. **Suitability for use.** Customer acknowledges and agrees that it is solely responsible for compliance with all legal, regulatory and safety-related requirements concerning its products, and any use of Silergy components in its applications, notwithstanding any applications-related information or support that may be provided by Silergy. Silergy products are not designed, authorized or warranted to be suitable for use in life support, life-critical or safety-critical systems or equipment, nor in applications where failure or malfunction of a Silergy product can reasonably be expected to result in personal injury, death or severe property or environmental damage. Silergy assumes no liability for inclusion and/or use of Silergy products in such equipment or applications and therefore such inclusion and/or use is at the customer's own risk.

5. **Terms and conditions of commercial sale.** Silergy products are sold subject to the standard terms and conditions of commercial sale, as published at <http://www.silergy.com/stdterms>, unless otherwise agreed in a valid written individual agreement specifically agreed to in writing by an authorized officer of Silergy. In case an individual agreement is concluded only the terms and conditions of the respective agreement shall apply. Silergy hereby expressly objects to and denies the application of any customer's general terms and conditions with regard to the purchase of Silergy products by the customer.

6. **No offer to sell or license.** Nothing in this document may be interpreted or construed as an offer to sell products that is open for acceptance or the grant, conveyance or implication of any license under any copyrights, patents or other industrial or intellectual property rights. Silergy makes no representation or warranty that any license, either express or implied, is granted under any patent right, copyright, mask work right, or other intellectual property right. Information published by Silergy regarding third-party products or services does not constitute a license to use such products or services or a warranty or endorsement thereof. Use of such information may require a license from a third party under the patents or other intellectual property of the third party, or a license from Silergy under the patents or other intellectual property of Silergy.

For more information, please visit: [www.silergy.com](http://www.silergy.com)

© 2021 Silergy Corp.

**All Rights Reserved.**